

RYOBI®

RCS2340B

ORIGINAL INSTRUCTIONS

Electric Chainsaw





Important!

It is essential that you read the instructions in this manual before assembling, operating and maintaining the product.

Subject to technical modification.



Safety, performance, and dependability have been given top priority in the design of your electric chainsaw.

INTENDED USE

The electric chainsaw is only intended for use outdoors. For safety reasons, the product must be adequately controlled by using two-handed operation at all times.

The product is designed for cutting branches, trunks, logs, and beams of a diameter determined by the cutting length of the guide bar. It is only designed to cut wood. It is only to be used in domestic application by adults who have received adequate training on the hazards and preventative measures/actions to be taken while using the product.

The product is not to be used by children or by persons not wearing adequate personal protective equipment and clothing. It is also not to be used for professional tree services.

Do not use the product for any other purpose.

⚠ WARNING

When using the product, the safety rules must be followed. For your own safety and that of bystanders, you must read and fully understand these instructions before operating the product. You should attend a professionally organised course on the use and maintenance of chainsaws, preventative actions, and first aid. Please keep these instructions safe for later use.

⚠ WARNING

Chainsaws are potentially dangerous tools. Accidents involving the use of chainsaws often result in loss of limbs or death. It is not just the chainsaw that is the hazard. Falling branches, toppling trees, rolling logs can all kill. Diseased or rotting timber poses additional hazards. You should assess your capability of completing the task safely. If there is any doubt, leave it to a professional tree surgeon.

GENERAL POWER TOOL SAFETY WARNINGS

⚠ WARNING

Read all safety warnings and all instructions. Failure to follow the warnings and instructions may result in electric shock, fire and/or serious injury.

Save all warnings and instructions for future reference.

The term "power tool" in the warnings refers to your mains-operated (corded) power tool or battery-operated (cordless) power tool.

WORK AREA SAFETY

- **Keep work area clean and well lit.** Cluttered or dark areas invite accidents.
- **Do not operate power tools in explosive atmospheres, such as in the presence of flammable**

liquids, gases or dust. Power tools create sparks which may ignite the dust or fumes.

- **Keep children and bystanders away while operating a power tool.** Distractions can cause you to lose control.

ELECTRICAL SAFETY

- **Power tool plugs must match the outlet. Never modify the plug in any way. Do not use any adapter plugs with earthed (grounded) power tools.** Unmodified plugs and matching outlets will reduce risk of electric shock.
- **Avoid body contact with earthed or grounded surfaces, such as pipes, radiators, ranges and refrigerators.** There is an increased risk of electric shock if your body is earthed or grounded.
- **Do not expose power tools to rain or wet conditions.** Water entering a power tool will increase the risk of electric shock.
- **Do not abuse the cord. Never use the cord for carrying, pulling or unplugging the power tool. Keep cord away from heat, oil, sharp edges or moving parts.** Damaged or entangled cords increase the risk of electric shock.
- **When operating a power tool outdoors, use an extension cord suitable for outdoor use.** Use of a cord suitable for outdoor use reduces the risk of electric shock.
- **If operating a power tool in a damp location is unavoidable, use a residual current device (RCD) protected supply.** Use of an RCD reduces the risk of electric shock.

PERSONAL SAFETY

- **Stay alert, watch what you are doing and use common sense when operating a power tool. Do not use a power tool while you are tired or under the influence of drugs, alcohol or medication.** A moment of inattention while operating power tools may result in serious personal injury.
- **Use personal protective equipment. Always wear eye protection.** Protective equipment such as dust mask, non-skid safety shoes, hard hat or hearing protection used for appropriate conditions will reduce personal injuries.
- **Prevent unintentional starting. Ensure the switch is in the off-position before connecting to power source and/or battery pack, picking up or carrying the tool.** Carrying power tools with your finger on the switch or energising power tools that have the switch on invites accidents.
- **Remove any adjusting key or wrench before turning the power tool on.** A wrench or a key left attached to a rotating part of the power tool may result in personal injury.
- **Do not overreach. Keep proper footing and balance at all times.** This enables better control of the power tool in unexpected situations.
- **Dress properly. Do not wear loose clothing or jewellery. Keep your hair, clothing and gloves away**

from moving parts. Loose clothes, jewellery or long hair can be caught in moving parts.

- **If devices are provided for the connection of dust extraction and collection facilities, ensure these are connected and properly used.** Use of dust collection can reduce dust-related hazards.

POWER TOOL USE AND CARE

- **Do not force the power tool. Use the correct power tool for your application.** The correct power tool will do the job better and safer at the rate for which it was designed.
- **Do not use the power tool if the switch does not turn it on and off.** Any power tool that cannot be controlled with the switch is dangerous and must be repaired.
- **Disconnect the plug from the power source and/or the battery pack from the power tool before making any adjustments, changing accessories or storing power tools.** Such preventive safety measures reduce the risk of starting the power tool accidentally.
- **Store idle power tools out of the reach of children and do not allow persons unfamiliar with the power tool or these instructions to operate the power tool.** Power tools are dangerous in the hands of untrained users.
- **Maintain power tools. Check for misalignment or binding of moving parts, breakage of parts and any other condition that may affect the power tool's operation. If damaged, have the power tool repaired before use.** Many accidents are caused by poorly maintained power tools.
- **Keep cutting tools sharp and clean.** Properly maintained cutting tools with sharp cutting edges are less likely to bind and are easier to control.
- **Use the power tool, accessories and tool bits etc, in accordance with these instructions, taking into account the working conditions and the work to be performed.** Use of the power tool for operations different from those intended could result in a hazardous situation.
- **Keep handles and grasping surfaces dry, clean and free from oil and grease.** Slippery handles and grasping surfaces do not allow for safe handling and control of the tool in unexpected situations.

SERVICE

- **Have your power tool serviced by a qualified repair person using only identical replacement parts.** This will ensure that the safety of the power tool is maintained.

ADDITIONAL GENERAL SAFETY WARNINGS

- Some regions have regulations that restrict the use of the product. Check with your local authority for advice.
- Never allow children or people unfamiliar with the instructions to use the product. Local regulations may restrict the age of the operator.
- Ensure before each use that all controls and safety devices function correctly. Do not use the power tool if the "off" switch does not stop the motor.

- Wear full eye and hearing protection, strong sturdy gloves, as well as head protection while operating the product. Use a face mask if operation is dusty.
- Do not wear loose fitting clothing, short trousers, or jewellery of any kind.
- Secure long hair so it is above shoulder level to prevent entanglement in moving parts.
- Beware of thrown, flying, or falling objects. Keep all bystanders, children, and animals at least 15 m away from work area.
- Do not operate in poor lighting. The operator requires a clear view of the work area to identify potential hazards.
- Use of hearing protection reduces the ability to hear warnings (shouts or alarms). The operator must pay extra attention to what is going on in the working area.
- Operating similar tools nearby increases both the risk of hearing injury and the potential for other persons to enter your working area.
- Keep firm footing and balance. Do not overreach. Overreaching can result in loss of balance and can increase the risk of kickback.
- Keep all parts of your body away from any moving part.
- Inspect the product before each use. Check for correct operation of all controls, including the chain brake. Check for loose fasteners, make sure all guards, and handles are properly and securely attached. Replace any damaged parts before use.
- Do not modify the product in any way or use parts and accessories which are not recommended by the manufacturer.
- A power spike causes voltage fluctuations and may affect other electrical products in the same power line. Connect the product to a power supply with an impedance equal or less than 0.33 Ω to minimize voltage fluctuations. Contact your electric power supplier for further clarification.

⚠ WARNING

If the product is dropped, suffers heavy impact or begins to vibrate abnormally, immediately stop the product and inspect for damage or identify the cause of the vibration. Any damage should be properly repaired or replaced by an authorised service centre.

- Electrical power should be supplied via a residual current device (RCD) with a tripping current of not more than 30 mA.
- If you need to use an extension cable, ensure it is suitable for outdoor use and has a current capacity sufficient to supply your product. Check it before every use for damage. Always uncoil it during use because coiled cables can overheat. Damaged extension cables should not be repaired; they should be replaced with an equivalent type.
- Before every use, examine the supply cord for damage. If there are signs of damage, it must be replaced by a special cord or assembly at an authorised service centre to avoid a hazard.

- Make sure the power cord is positioned so that it cannot be damaged by the cutting means and will not be stepped on, tripped over, or otherwise subjected to damage or stress.
- Never pick up or carry the product by the electric cable.
- Never pull the power cord to disconnect from the power supply.
- Keep the power cord away from heat, oil, and sharp edges.

CHAINSAW SAFETY WARNINGS

- **Keep all parts of the body away from the saw chain when operating the product. Before you start the chainsaw, make sure the saw chain is not contacting anything.** A moment of inattention while operating chainsaws may cause entanglement of your clothing or body with the saw chain.
- **Always hold the chainsaw with your right hand on the rear handle and your left hand on the front handle.** Holding the chainsaw with a reversed hand configuration increases the risk of personal injury and should never be done.
- **Hold the power tool by gripping surface only, because the saw chain may contact hidden wiring or its own cord.** Saw chains contacting a "live" wire may make exposed metal parts of the power tool "live" and could give the operator an electric shock.
- **Wear safety glasses and hearing protection. Further protective equipment for head, hands, legs and feet is recommended.** Adequate protective clothing will reduce personal injury by flying debris or accidental contact with the saw chain.
- **Do not operate a chainsaw in a tree.** Operation of a chainsaw while up in a tree may result in personal injury.
- **Always keep proper footing and operate the chainsaw only when standing on fixed, secure and level surface.** Slippery or unstable surfaces such as ladders may cause a loss of balance or control of the chainsaw.
- **When cutting a limb that is under tension be alert for spring back.** When the tension in the wood fibres is released the spring loaded limb may strike the operator and/or throw the chainsaw out of control.
- **Use extreme caution when cutting brush and saplings.** The slender material may catch the saw chain and be whipped toward you or pull you off balance.
- **Carry the chainsaw by the front handle with the chainsaw switched off and away from your body. When transporting or storing the chainsaw always fit the guide bar cover.** Proper handling of the chainsaw will reduce the likelihood of accidental contact with the moving saw chain.
- **Follow instructions for lubricating, chain tensioning and changing accessories.** Improperly tensioned or lubricated chain may either break or increase the chance for kickback.

- **Keep handles dry, clean, and free from oil and grease.** Greasy, oily handles are slippery causing loss of control.
- **Cut wood only. Do not use chainsaw for purposes not intended. For example: do not use chainsaw for cutting plastic, masonry or non-wood building materials.** Use of the chainsaw for operations different than intended could result in a hazardous situation.

Causes and operator prevention of kickback:

Kickback may occur when the nose or tip of the guide bar touches an object, or when the wood closes in and pinches the saw chain in the cut.

Tip contact in some cases may cause a sudden reverse reaction, kicking the guide bar up and back towards the operator.

Pinching the saw chain along the top of the guide bar may push the guide bar rapidly back towards the operator.

Either of these reactions may cause you to lose control of the saw which could result in serious personal injury. Do not rely exclusively upon the safety devices built into your saw. As a chainsaw user, you should take several steps to keep your cutting jobs free from accident or injury.

Kickback is the result of tool misuse and/or incorrect operating procedures or conditions and can be avoided by taking proper precautions as given below:

- **Maintain a firm grip, with thumbs and fingers encircling the chainsaw handles, with both hands on the saw with your body and arms positioned to allow you to resist kickback forces.** Kickback forces can be controlled by the operator, if proper precautions are taken. Do not let go of the chainsaw.
- **Do not overreach and do not cut above shoulder height.** This helps prevent unintended tip contact and enables better control of the chainsaw in unexpected situations.
- **Only use replacement bars and chains specified by the manufacturer.** Incorrect replacement bars and chains may cause chain breakage and/or kickback.

ADDITIONAL CHAINSAW SAFETY WARNINGS

- It is recommended to cut logs on a saw-horse or cradle when operating the product the first time.
- Ensure all guards, handles and spiked bumper are properly fitted and are in good condition.
- Persons using the product should be in good health. The product is heavy, so the operator must be physically fit. The operator should be alert, have a good vision, mobility, balance, and manual dexterity. If there is any doubt, do not operate the product.
- Do not start using the product until you have a clear work area, secure footing, and a planned retreat path away from the falling tree.
- Beware of the emission of lubricant mist and saw dust. Wear a mask or respirator, if required.
- Always keep the power cable tidy and away from the area of cutting. Apart from the danger of electrocution, untidy cables cause falls and trips.

- Do not cut vines and/or small undergrowth (less than 75 mm in diameter).
- Always hold the chainsaw with both hands during operation. Use a firm grip with thumbs and fingers encircling the chainsaw handles. Right hand must be on the rear handle and left hand on the front handle.
- Before starting the product, make sure the saw chain is not contacting any object.
- Do not modify the product in any way or use it to power any attachments or devices not recommended by the manufacturer for your saw.
- There should be a first-aid kit containing large wound dressings and a means to summon attention (e.g., whistle) close to the operator. A larger more comprehensive kit should be reasonably nearby.
- Wear a helmet at all times when operating the product. A helmet, equipped with mesh visor, can help reduce the risk of injury to the face and the head if kickback occurs.
- An incorrectly tensioned chain can jump off the guide bar and could result in serious injury or fatality. The length of chain depends on the temperature. Check the tension frequently.
- You should get used to your new chainsaw by making simple cuts on securely supported wood. Do this whenever you have not operated the saw for some time.
- To reduce the risk of injury associated with contacting moving parts, always stop the motor, apply chain brake, and remove the plug from the power outlet. Make sure all moving parts have come to a complete stop:
 - before leaving the product unattended
 - before cleaning or clearing a blockage
 - before installing or removing attachments
 - before checking, conducting maintenance, or working on the product
- The size of the work area depends on the job being performed as well as the size of the tree or work piece involved. For example, felling a tree requires a larger work area than making other cuts, i.e., bucking cuts, etc. The operator needs to be aware and in control of everything happening in this work area.
- Do not cut with your body in line with the guide bar and chain. If you do experience kickback this will help prevent the chain coming into contact with your head or body.
- Do not use a back-and-forward sawing motion, let the chain do the work, keep the chain sharp and don't try to push the chain through the cut.
- Do not put pressure on the saw at the end of the cut. Be ready to take on the weight of the saw as it cuts free from the wood. Failure to do so could result in possible serious personal injury.
- Do not stop the saw in the middle of a cutting operation. Keep the saw running until it exits the cut.

Personal protective equipment

Good quality personal protective equipment, as used by professionals, will help reduce the risk of injury to the operator. The following items should be used when operating the product:

- **Safety helmet**
- **Hearing protection**
- **Eye and face protection**
- **Gloves**
- **Leg protection (chaps)**
- **Chainsaw safety boots**
- **Chainsaw jackets for upper body protection**

INSTRUCTIONS CONCERNING THE PROPER TECHNIQUES FOR BASIC FELLING, LIMBING, AND CROSS-CUTTING

Understanding the forces within the wood

When you understand the directional pressures and stresses inside the wood you can reduce the "pinches" or at least expect them during your cutting. Tension in the wood means the fibers are being pulled apart and if you cut in this area, the "kerf" or cut will tend to open as the saw goes through. If a log is being supported on a saw horse and the end is hanging unsupported over the end, then tension is created on the upper surface due to the weight of the overhanging log stretching the fibers. Likewise, the underside of the log will be in compression and the fibers are being pushed together. If a cut is made in this area, the kerf will have the tendency to close up during the cut. This would pinch the blade.

Felling a tree

See page 19 - 20.

When bucking and felling operations are being performed by two or more persons at the same time, the felling operations should be separated from the bucking operation by a distance of at least twice the height of the tree being felled. Trees should not be felled in a manner that would endanger any person, strike any utility line or cause any property damage. If the tree does make contact with any utility line, the company should be notified immediately.

The chainsaw operator should keep on the uphill side of the terrain as the tree is likely to roll or slide downhill after it is felled.

An escape path should be planned and cleared as necessary before cuts are started. The escape path should extend back and diagonally to the rear of the expected line of fall.

Before felling starts, consider the natural lean of the tree, the location of larger branches, and the wind direction to judge which way the tree will fall.

Remove dirt, stones, loose bark, nails, staples and wire from the tree.

Do not attempt to fell trees which are rotten or have been damaged by wind, fire, lightning, etc. This is extremely dangerous and should only be completed by professional tree surgeons.



- **Notching undercut**

See page 19 - 20.

Make the notch 1/3 the diameter of the tree, perpendicular to the direction of the fall. Make the lower horizontal notching cut first. This will help to avoid pinching either the saw chain or the guide bar when the second notch is being made.

- **Felling back cut**

See page 19 - 20.

Make the felling back cut at least 50 mm / 2 in higher than the horizontal notching cut. Keep the felling-back cut parallel to the horizontal notching cut. Make the felling back cut so enough wood is left to act as a hinge. The hinge wood keeps the tree from twisting and falling in the wrong direction. Do not cut through the hinge.

As the felling gets close to the hinge, the tree should begin to fall. If there is any chance that the tree may not fall in desired direction or it may rock back and bind the saw chain, stop cutting before the felling back cut is complete and use wedges of wood, plastic or aluminium to open the cut and drop the tree along the desired line of fall.

When the tree begins to fall remove the chainsaw from the cut, stop the motor, put the chainsaw down, and use the retreat path planned. Be alert for falling overhead limbs and watch your footing.

Removing buttress roots

See page 18.

A buttress root is a large root extending from the trunk of the tree above the ground. Remove large buttress roots prior to felling. Make the horizontal cut into the buttress first, followed by the vertical cut. Remove the resulting loose section from the work area. Follow the correct tree felling procedure after you have removed the large buttress roots.

Push and pull

The reaction force is always opposite to the direction the chain is moving. Thus, the operator must be ready to control the tendency for the product to pull away (forward motion) when cutting on the bottom edge of the bar. Engage always firmly the bumper spike to avoid such movement. The product can be pushed backwards (towards the operator) when cutting along the top edge. To avoid this make sure the chain is not jammed when cutting along the top edge.

Saw jammed in the cut

Stop the chainsaw and make it safe. Do not try to force the chain and bar out of the cut as this is likely to break the chain, which may swing back and strike the operator. This situation normally occurs because the wood is incorrectly supported which forces the cut to close under compression, thereby pinching the blade. If adjusting the support does not release the bar and chain, use wooden wedges or a lever to open the cut and release the saw. Never try to start the chainsaw when the guide bar is already in a cut or kerf.

Skating / Bouncing

When the chainsaw fails to dig in during a cut, the guide bar can begin hopping or dangerously skidding along the surface of the log or branch, possibly resulting in the loss of control of the chainsaw. To prevent or reduce skating or bouncing, always use the saw with both hands. Make sure the saw chain establishes a groove for cutting.

Never cut small, flexible branches or brushes with your chainsaw. Their size and flexibility can easily cause the saw to bounce towards you or bind up with enough force to cause a kickback. The best tool for that kind of work is a hand saw, pruning shears, an axe or other hand tools.

Bucking a log

See page 21.

Bucking is cutting a log into lengths. It is important to make sure your footing is firm and your weight is evenly distributed on both feet. When possible, the log should be raised and supported by the use of limbs, logs or chocks. Follow the simple directions for easy cutting. When the log is supported along its entire length, it is cut from the top (overbuck).

When the log is supported on one end, cut 1/3 the diameter from the underside (underbuck). Then make the finished cut by overbucking to meet the first cut.

When the log is supported on both ends, cut 1/3 the diameter from the top (overbuck). Then make the finished cut by underbucking the lower 2/3 to meet the first cut.

When bucking on a slope always stand on the uphill side of the log. When "cutting through", to maintain complete control release the cutting pressure near the end of the cut without relaxing your grip on the chainsaw handles. Don't let the chain contact the ground. After completing the cut, wait for the saw chain to stop before you move the chainsaw. Always stop the motor before moving from tree to tree.

Limbing a tree

See page 22.

Limbing is removing the branches from a fallen tree. When limbing, leave larger lower limbs to support the log off the ground. Remove the small limbs in one cut. Branches under tension should be cut from the bottom up to avoid binding the chainsaw.

Springpoles

See page 22.

A springpole is any log, branch, rooted stump, or sapling which is bent under tension by other wood so that it springs back if the wood holding it is cut or removed.

On a fallen tree, a rooted stump has a high potential of springing back to the upright position during the bucking cut to separate the log from the stump. Watch out for springpoles—they are dangerous. Do not attempt to cut bent branches or stumps which are under tension unless you are professionally trained and competent to do so.





⚠ WARNING

Springpoles are dangerous and could strike the operator, causing the operator to lose control of the chainsaw. This could result in severe or fatal injury to the operator. This should be done by trained users.

TRANSPORTATION AND STORAGE

See page 27 - 30.

- Stop the product and disconnect it from the power supply. Allow the product to cool down before storing or transporting.
- Clean all foreign material from the product. Store it in a cool, dry, and well-ventilated place that is inaccessible to children. Keep away from corrosive agents such as garden chemicals and de-icing salts. Do not store outdoors.
- Fit the guide bar cover before storing the product or during transportation.
- For transportation, secure the product against movement or falling to prevent injury to persons or damage to the product.

MAINTENANCE

Always keep the product in good working condition.

⚠ WARNING

Use only original manufacturer's replacement parts, accessories, and attachments. Failure to do so can cause possible injury, poor performance, and may void your warranty.

⚠ WARNING

Servicing requires extreme care and knowledge and should be performed only by a qualified service technician. Have the product serviced by an authorised service centre only. When servicing, use only original replacement parts.

⚠ WARNING

Disconnect the product from the power supply before adjustment, maintenance, or cleaning. Failure to do so could result in serious personal injury.

- You may only make adjustments or repairs described in this manual. For other repairs, have the product serviced by an authorised service centre only.
- Consequences of improper maintenance, removal, or modification of safety features like the chain brake, ignition switch, hand guard (front and back), spiked bumper, chain catcher, guide bar, low-kickback saw chain may cause the safety features to not function correctly, thus increasing the potential for serious injury. Keep the product professionally maintained and safe.
- Sharpening the chain safely is a skilled task. Therefore,

the manufacturer strongly recommends that a worn or dull chain is replaced with a new one, available at your authorised service centre. The part number is available in the product specification table in this manual.

- Follow instructions for lubricating and chain tension checking and adjustment.
- After each use, clean the product with a soft dry cloth.
- Check all nuts, bolts, and screws at frequent intervals for security to ensure the product is in safe working condition. Any part that is damaged should be properly repaired or replaced by an authorised service centre.

RESIDUAL RISKS

Even when the product is used as prescribed, it is still impossible to completely eliminate certain residual risk factors. The following hazards may arise during use, and the operator should pay special attention to avoid the following:

- Injury caused by vibration
 - Always use the right tool for the job. Use designated handles. Restrict working time and exposure.
- Exposure to noise can cause hearing injury.
 - Wear hearing protection and limit exposure.
- Contact with exposed saw teeth of the chain (cutting hazards).
- Unforeseen, abrupt movement or kickback of the guide bar (cutting hazards).
- Parts ejected from the saw chain (cutting/injection hazards).
- Thrown out pieces of the work piece (wood chips, splinters).
- Inhalation of saw dust and particles or emission from the petrol engine.
- Skin contact with petrol/oil.

RISK REDUCTION

It has been reported that vibrations from hand-held tools may contribute to a condition called Raynaud's Syndrome in certain individuals. Symptoms may include tingling, numbness and blanching of the fingers, usually apparent upon exposure to cold. Hereditary factors, exposure to cold and dampness, diet, smoking and work practices are all thought to contribute to the development of these symptoms. There are measures that can be taken by the operator to possibly reduce the effects of vibration:

- Keep your body warm in cold weather. When operating the unit wear gloves to keep the hands and wrists warm. It is reported that cold weather is a major factor contributing to Raynaud's Syndrome.
- After each period of operation, exercise to increase blood circulation.
- Take frequent work breaks. Limit the amount of exposure per day.
- Protective gloves available from professional chainsaw retailers are designed specifically for chainsaw use, which give protection, good grip and also reduce the effect of handle vibration.



If you experience any of the symptoms of this condition, immediately discontinue use and see your physician.

⚠ WARNING

Injuries may be caused, or aggravated, by prolonged use of a tool. When using any tool for prolonged periods, ensure you take regular breaks.

SAFETY DEVICES

Low kick-back saw chain

A low-kickback saw chain helps to reduce the possibility of a kickback event.

The rakers (depth gauges) ahead of each cutter can minimize the force of a kickback reaction by preventing the cutters from digging in too deeply. Only use replacement guide bar and chain combinations recommended by the manufacturer.

As saw chains are sharpened, they lose some of the low kickback qualities and extra caution is required. For your safety, replace saw chains when cutting performance decreases.

Spiked bumper

The integral bumper spike may be used as a pivot when making a cut. It helps to keep the body of the chainsaw steady while cutting. When cutting, push the product forward until the spikes dig into the edge of the wood, then by moving the rear handle up or down in the direction of the cutting line it can help ease the physical strain of cutting

Guide bars

Generally, guide bars with small radius tips have somewhat lower potential for kickback. You should use a guide bar and matching chain which is just long enough for the job. Longer bars increase the risk of loss of control during sawing. Regularly check the chain tension. When cutting smaller branches (less than the full length of the guide bar) the chain is more likely to be thrown off if the tension is not correct.

Chain brake

Chain brakes are designed to quickly stop the chain from rotating. When the chain brake lever/hand guard is pushed towards the bar, the chain should stop immediately. A chain brake does not prevent kickback. It only lowers the risk of injury should the chain bar contact the operator's body during a kickback event. The chain brake should be tested before each use for correct operation in both the run and brake positions.

Chain catcher

A chain catcher prevents the saw chain from being thrown back towards the operator if the saw chain comes loose or breaks.

ASSEMBLY

⚠ WARNING

If any parts are damaged or missing, do not operate the product until the parts are replaced. Failure to heed this warning could result in serious personal injury.

ADJUSTING THE CHAIN TENSION

See page 25.

1. Disconnect the product from the power supply. Wear protective gloves.
2. To correct the chain tension, fully loosen the chain tension/guide bar locking knob, then tighten the chain tension/guide bar locking knob by turning it clockwise until it locks into place. Check the chain tension frequently.

The chain tension is correct when the gap between the cutter in the chain and the bar is between 3 mm - 4 mm. Pull the chain in the middle of the lower side of the bar downwards (away from the bar) and measure the distance between the bar and the chain cutters.

3. Tighten and lock the chain tension/guide bar locking knob by turning it clockwise.

OPERATION

ADDING CHAIN LUBRICATING OIL

See page 15.

⚠ WARNING

Never work without chain lubricant. If the saw chain is running without lubricant, the guide bar and saw chain can be damaged. It is essential to frequently check the oil level in the oil level gauge and before starting to use the chainsaw.

1. Clear surface around the oil cap to prevent contamination.
2. Unscrew and remove the cap from the oil tank.
3. Pour the oil into the oil tank and monitor the oil level gauge. Ensure that no dirt enters the oil tank while filling.
4. Put the oil cap back on and tighten it up. Wipe away any spillage.
5. One full oil tank will enable you to use the saw for 18 - 28 min.

HOLDING THE CHAIN SAW

See page 15.

Always hold the chain saw with your right hand on the rear handle and your left hand on the front handle. Grip both handles with the thumbs and fingers encircling the handles. Ensure that your left hand is holding the front handle so that your thumb is underneath.



⚠ WARNING

Always keep the power cable tidy and away from the area of cutting. Apart from the danger of electrocution, untidy cables cause falls and trips.

STARTING THE CHAIN SAW

See page 15.

1. Connect the product to a power outlet. Make sure the chain brake is in the run position by pulling back on the lever/hand guard.
2. To start the product: Press the trigger release, and then press the on/off trigger.

CHECKING AND OPERATING CHAIN BRAKE

1. Engage the chain brake by rotating your left hand around the front handle. Allow the back of your hand to push the chain brake lever/hand guard toward the bar while the chain is rotating rapidly. The chain should stop rotating immediately. Be sure to maintain both hands on the saw handles at all times.
2. Reset the chain brake back into the Run position by grasping the top of the chain brake lever/hand guard and pulling toward the front handle until you hear a click.

⚠ WARNING

If the chain brake does not stop the chain immediately, or if the chain brake will not stay in the run position without assistance, have the product serviced by an authorised service centre prior to use.

REPLACING GUIDE BAR AND SAW CHAIN

See page 23.

1. Disconnect the product from the power supply. Wear protective gloves.
2. Unlock the chain tension/guide bar locking knob by turning it counterclockwise until the sprocket cover comes loose.
3. Remove the sprocket cover. Remove the bar and saw chain from the product.
4. Remove the screw holding the guide bar to the chain tension assembly. Dispose the used bar and saw chain properly.
5. Mount the chain tension assembly on to the new bar and tighten the screw. Put the new chain in the correct direction onto the bar and make sure that the drive links are aligned in the bar groove.
6. Attach the bar to the chain saw and loop the chain around the drive sprocket.
Replace the sprocket cover.
7. Tighten and lock the chain tension/guide bar locking knob by turning it clockwise.
The chain tension is correct when the gap between the

cutter in the chain and the bar is between 3 mm - 4 mm. Pull the chain in the middle of the lower side of the bar downwards (away from the bar) and measure the distance between the bar and the chain cutters.

Adjust the chain tension. Refer to the "Adjusting chain tension" section.

⚠ WARNING

Improper chain sharpening increases the potential of kickback.

⚠ WARNING

Failure to replace or repair a damaged chain can cause serious injury.

⚠ WARNING

The saw chain is very sharp. Always wear protective gloves when performing maintenance to the chain.

INSPECTING AND CLEANING THE CHAIN BRAKE

See page 26.

- Always keep the chain brake mechanism clean by lightly brushing the linkage free from dirt.
- Always test the chain brake performance after cleaning. Refer to the "Operation - Checking and Operating Chain Brake" in this manual for additional information.

MAINTENANCE SCHEDULE

Daily check	
Power cable for damage	Before each use
Bar lubrication	Before each use
Chain tension	Before each use and frequently
Chain sharpness	Before each use, visual check
For damaged parts	Before each use
For loose fasteners	Before each use
Chain brake function	Before each use
Inspect and clean	
Bar	Before each use
Complete saw	After each use
Chain brake	Every 5 hours*

* Hours of operation



WHAT'S IN THE BOX

RCS2340B

- Chainsaw x1
- Guide bar cover x1
- Operator's manual x1

SYMBOLS ON THE PRODUCT

	Safety alert
	To reduce the risk of injury, user must read and understand operator's manual before using this product.
	Wear eye, ear and head protection.
	Wear non-slip safety footwear when using the product.
	Wear non-slip, heavy duty gloves.
	Remove plug from the mains immediately before maintenance or if cable is damaged or cut
	Beware of chain saw kickback and avoid contact with bar tip.
	Do not expose to rain or damp condition.
	Hold and operate the saw properly with both hands.
	Do not operate the saw using only one hand.
	Class II tool, double insulation
	Regulatory Compliance Mark (RCM). Product meets applicable regulatory requirements.
	Waste electrical products should not be disposed of with household waste. Please recycle where facilities exist. Check with your local authority or retailer for recycling advice.
	The guaranteed sound pressure level is 96 dB.
	The guaranteed sound power level is 107 dB
	Bar and chain lubricant



Chain brake

Rotate to lock or unlock the guide bar



Lock



Unlock



Moving direction of the chain.
(Marked under the sprocket cover)

SYMBOLS IN THIS MANUAL



Connect to power outlet.



Disconnect from power outlet.



Parts or accessories sold separately



Note



Warning



Wear eye and face protection.



Wear upper body protection.



Wear leg protection.



Stop the product.



The following signal words and meanings are intended to explain the levels of risk associated with this product.

DANGER

Indicates an imminently hazardous situation, which, if not avoided, will result in death or serious injury.

WARNING

Indicates a potentially hazardous situation, which, if not avoided, could result in death or serious injury.





⚠ CAUTION

Indicates a potentially hazardous situation, which, if not avoided, may result in minor or moderate injury.

CAUTION

Without safety alert symbol

Indicates a situation that may result in property damage.





WHAT'S IN THE BOX

RCS2340B

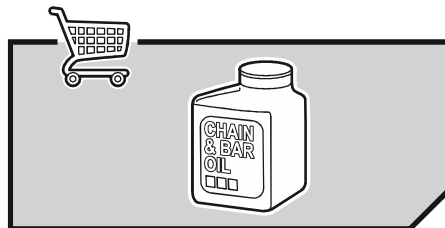
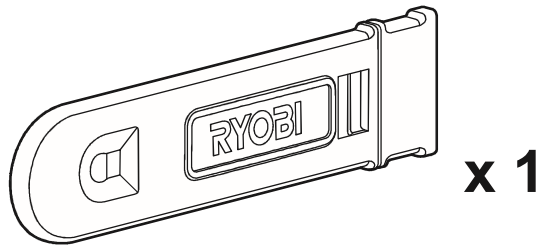
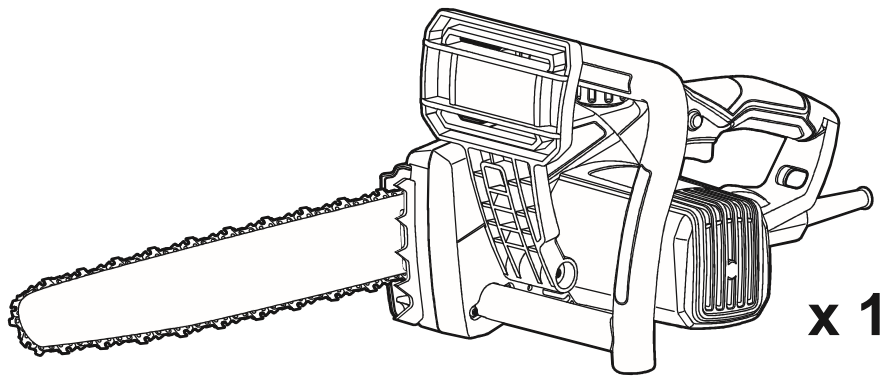

KNOW YOUR PRODUCT

- | | |
|---------------------------------|---|
| 1. Chain | 8. Chain lubricant cap |
| 2. Guide bar | 9. Cord retainer |
| 3. Front hand guard/Chain brake | 10. Switch trigger |
| 4. Front handle | 11. Sprocket cover |
| 5. Trigger release | 12. Chain tension/ Guide bar locking knob |
| 6. Rear handle | 13. Guide bar cover |
| 7. Spiked bumper | 14. Chain catcher |

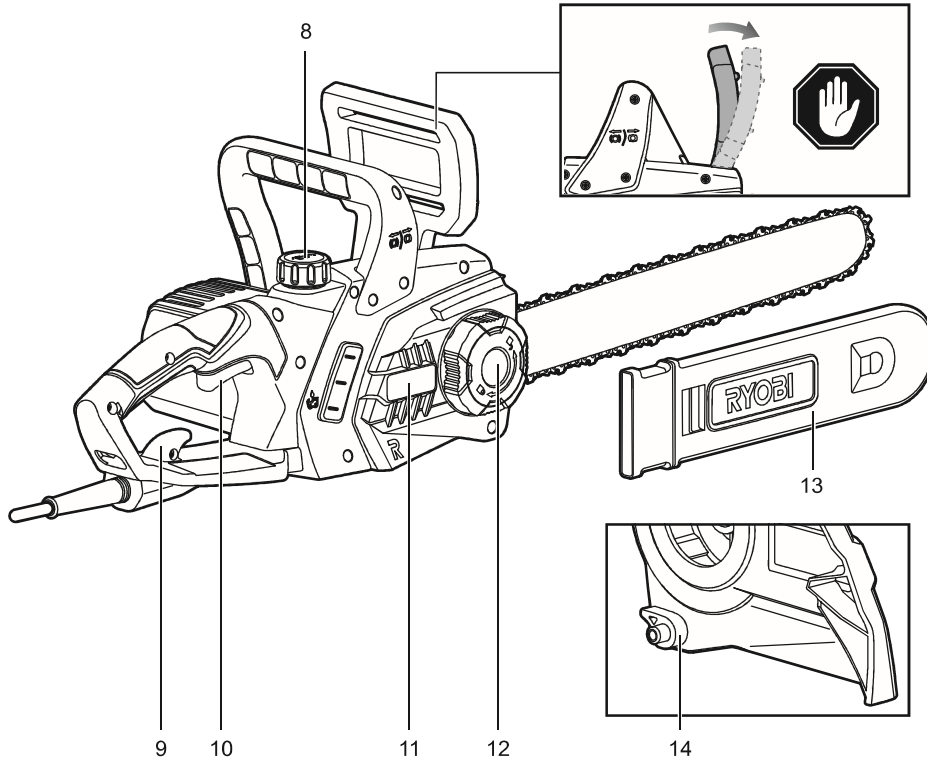
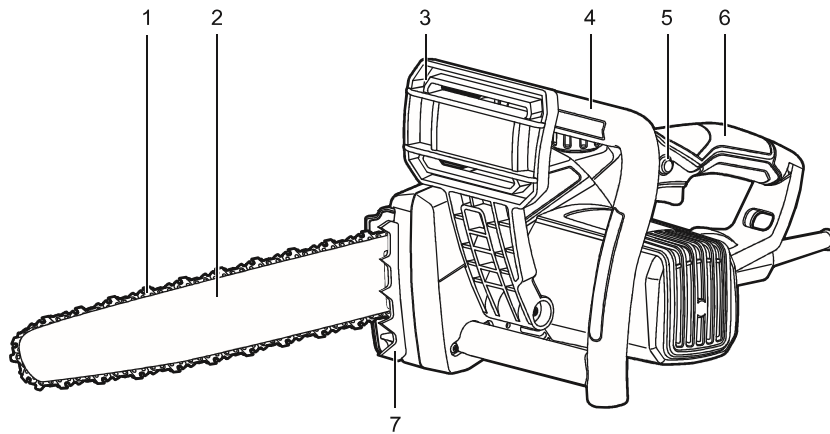

GETTING STARTED



Personal protective equipment (PPE)

Good quality personal protective equipment, as used by professionals, will help reduce the risk of injury to the operator.

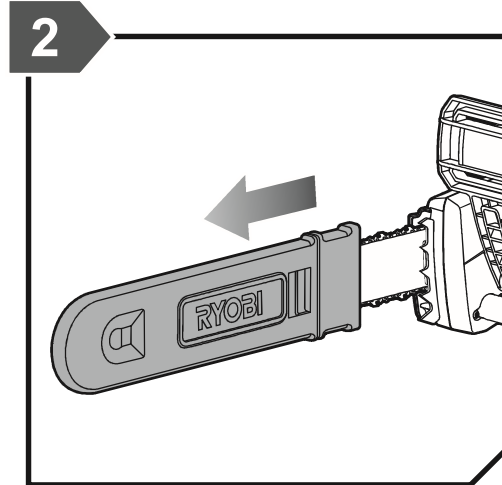

Remove the guide bar cover.

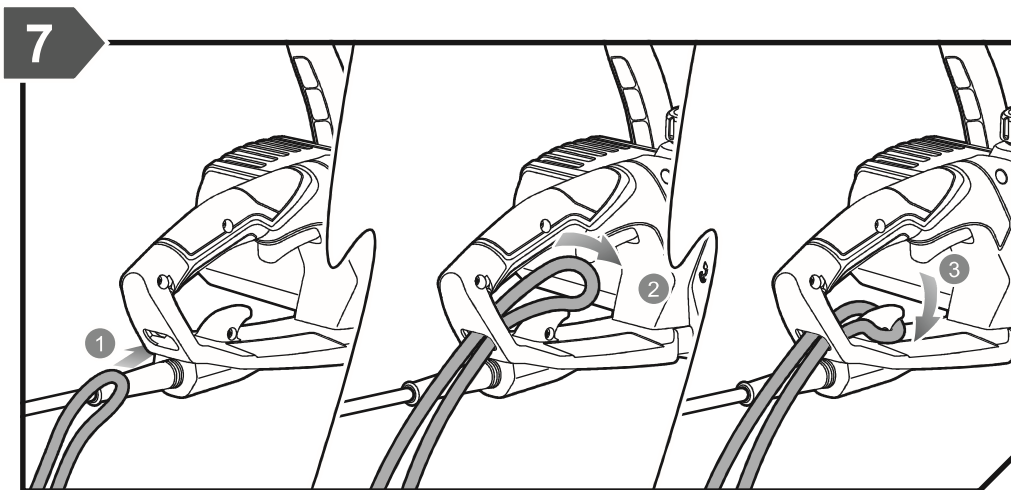

1. Secure the power cable by inserting it through the cable slot.
2. Loop the cable.
3. Run the cable loop through the cable hook.

GETTING STARTED

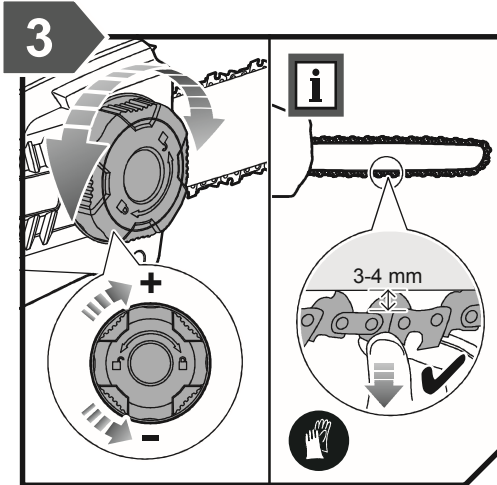

The chain tension is correct when the gap between the cutter in the chain and the bar is between 3 mm - 4 mm. Pull the chain in the middle of the lower side of the bar downwards (away from the bar) and measure the distance between the bar and the chain cutters.

To tighten the chain, turn the chain tension/guide bar locking knob clockwise. To loosen the chain, turn the chain tension/guide bar locking knob counterclockwise.

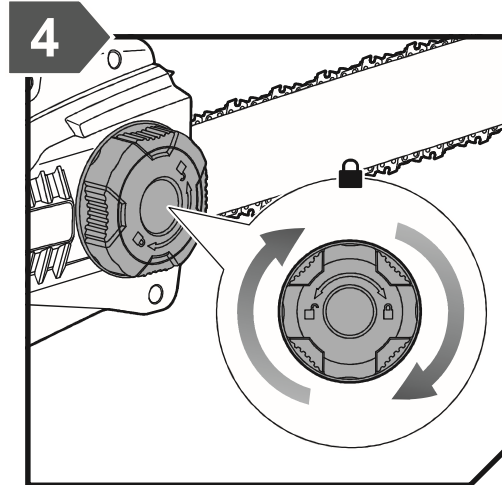

Tighten and lock the chain tension/guide bar locking knob by turning it clockwise.

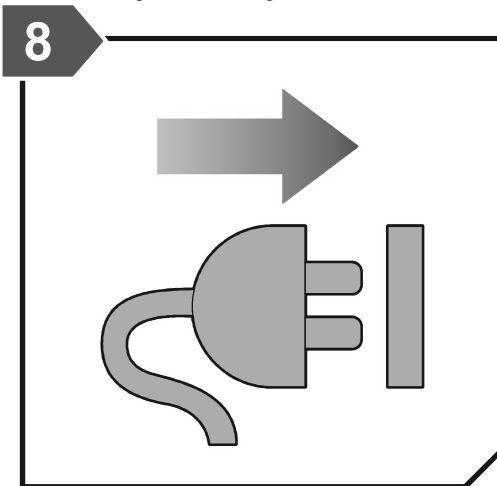

Connect the product to a power outlet.

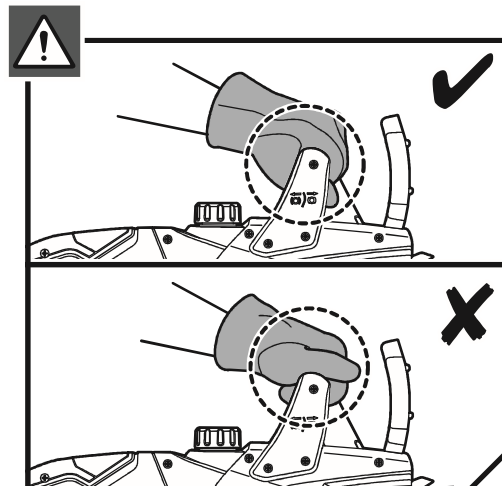

Always hold the product with your right hand at the rear handle and your left hand at the front handle. Grip both handles with the thumbs and fingers encircling the handles. Ensure that your left hand is holding the front handle so that your thumb is underneath.



OVERVIEW

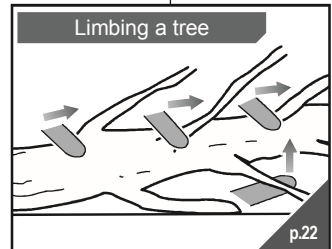
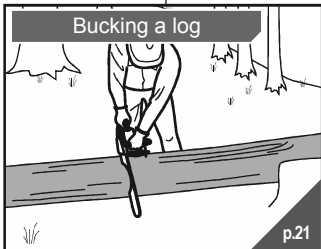
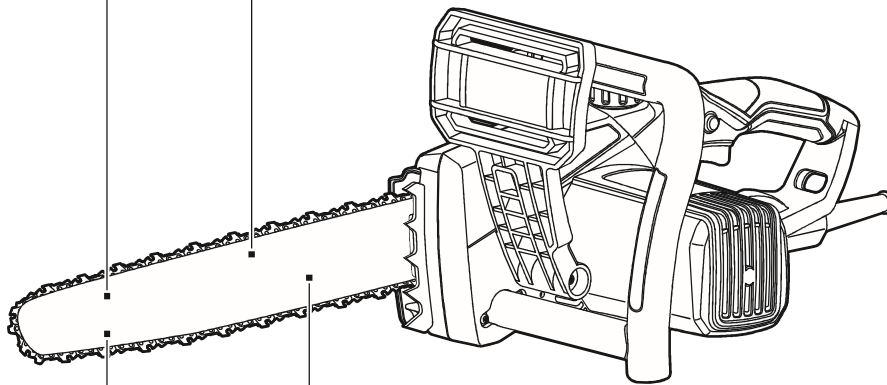
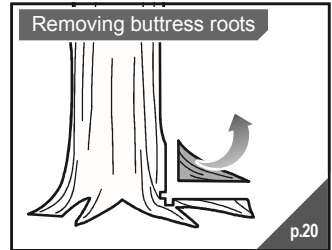
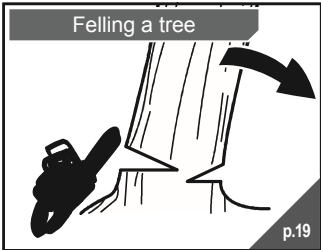

OVERVIEW

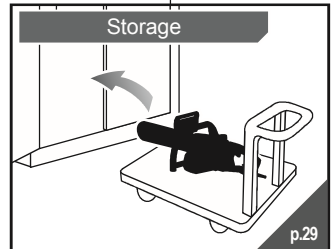
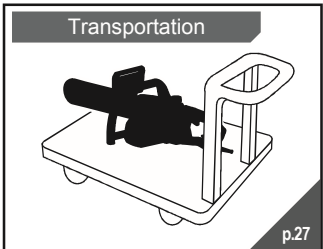
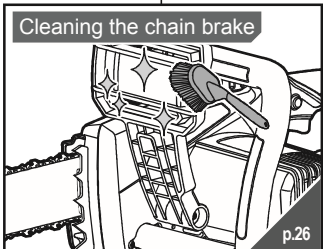
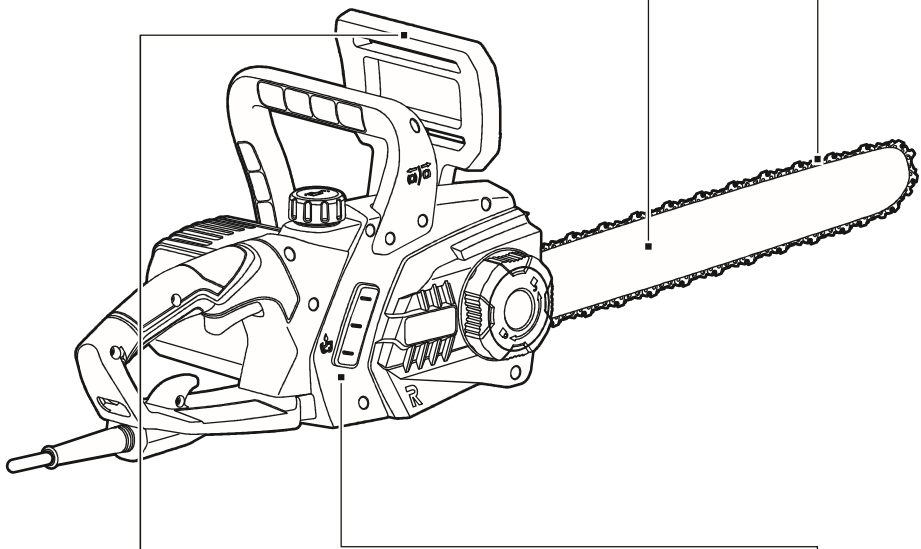
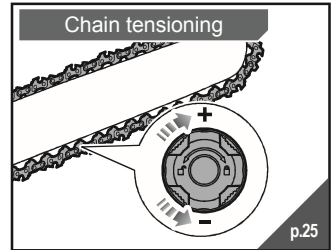
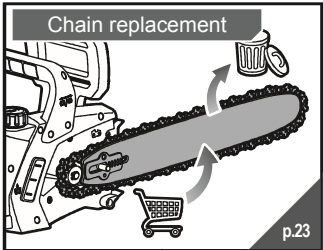

OPERATION

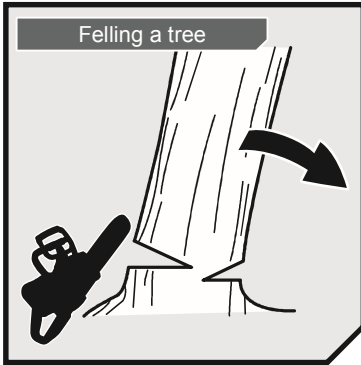

WARNING: Maintain a firm grip, with thumbs and fingers encircling the chainsaw handles, with both hands on the saw and position your body and arm to allow you to resist kickback forces. Kickback forces can be controlled by the operator, if proper precautions are taken. Do not let go of the chainsaw.

WARNING: Kickback may occur when the nose or tip of the guide bar touches an object, or when the wood closes in and pinches the saw chain in the cut.

WARNING: An escape path should be planned and cleared as necessary before cuts are started. The escape path should extend back and diagonally to the rear of the expected line of fall.

1. Make the felling back cut at least 5 cm / 2 in. higher than the horizontal notching cut. Keep the felling back cut parallel to the horizontal notching cut. Make the felling back cut so enough wood is left to act as a hinge. The hinge wood keeps the tree from twisting and falling in the wrong direction.

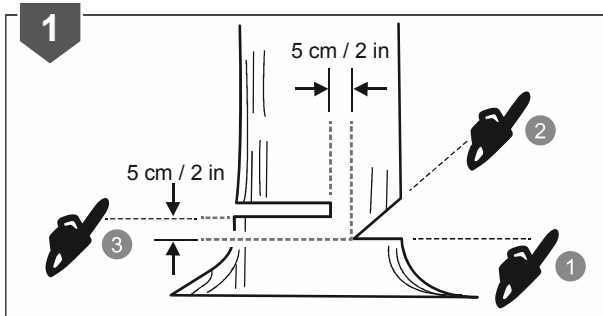
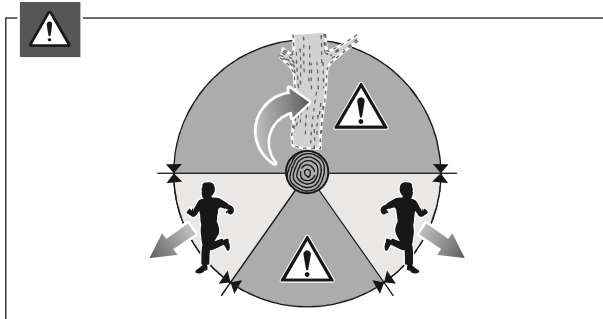
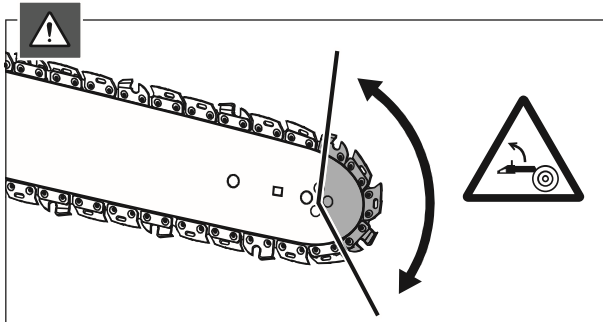
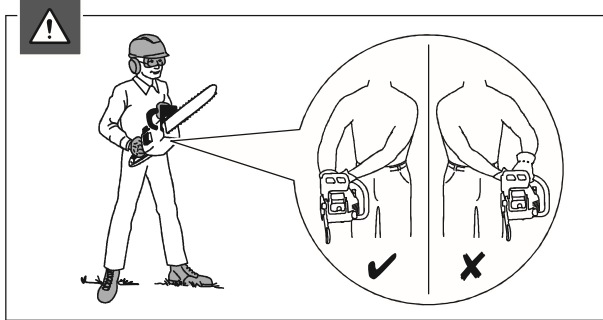

OPERATION

WARNING: Do not cut through the hinge.

- As the felling gets close to the hinge, the tree should begin to fall. If there is any chance that the tree may not fall in desired direction or it may rock back and bind the saw chain, stop cutting before the felling back cut is complete and use wedges of wood, plastic or aluminium to open the cut and drop the tree along the desired line of fall.

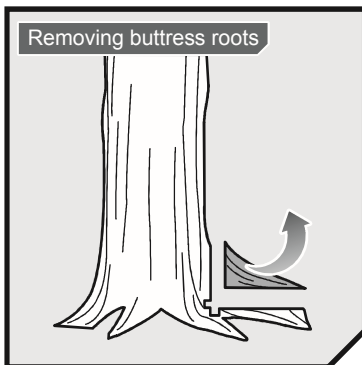
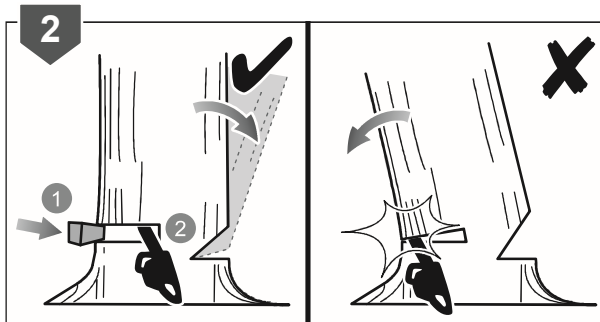
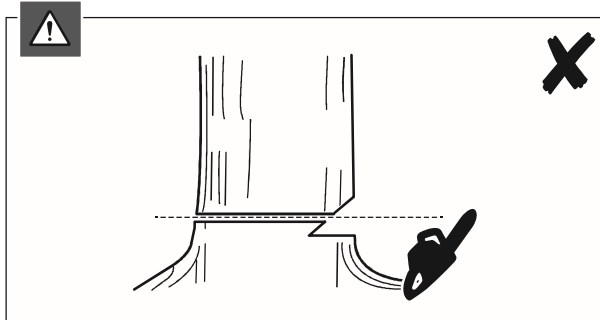

- A buttress root is a large root extending from the trunk of the tree above the ground. Remove large buttress roots prior to felling. Make the horizontal cut into the buttress first, followed by the vertical cut.
- Remove the resulting loose section from the work area. Follow the correct tree felling procedure after you have removed the large buttress roots.

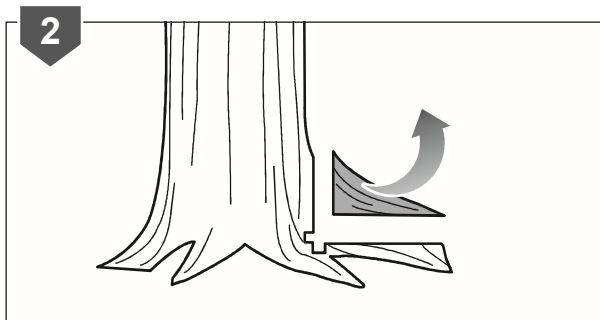
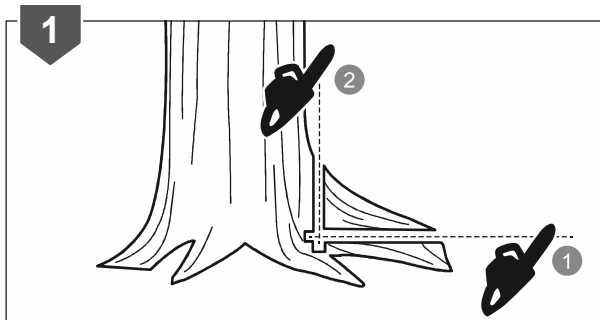

OPERATION

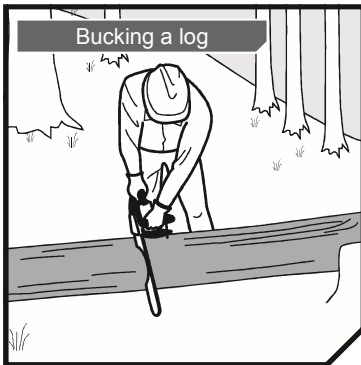

WARNING: Kickback may occur when the nose or tip of the guide bar touches an object, or when the wood closes in and pinches the saw chain in the cut.

WARNING: The reaction force is always opposite to the direction the chain is moving. Thus, the operator must be ready to control the tendency for the product to pull away (forward motion) when cutting on the bottom edge of the bar. Engage always firmly the bumper spike to avoid such movement. The product can be pushed backwards (towards the operator) when cutting along the top edge. To avoid this make sure the chain is not jammed when cutting along the top edge.

NOTE: When the log is supported on both ends, cut $1/3$ the diameter from the top (overbuck). Then make the finished cut by underbucking the lower $2/3$ to meet the first cut.

NOTE: When the log is supported on one end, cut $1/3$ the diameter from the underside (underbuck). Then make the finished cut by overbucking to meet the first cut.

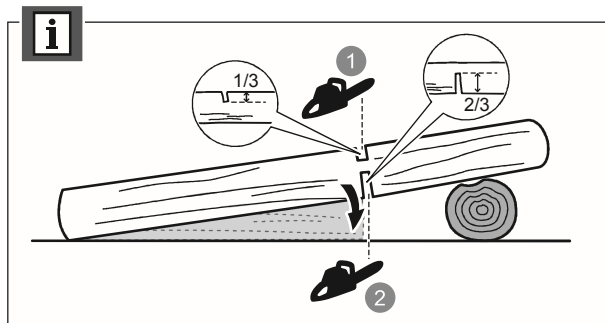
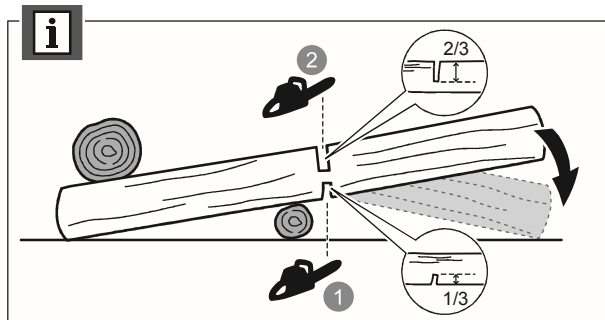
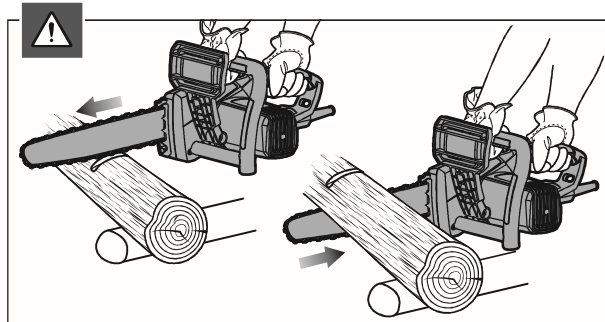
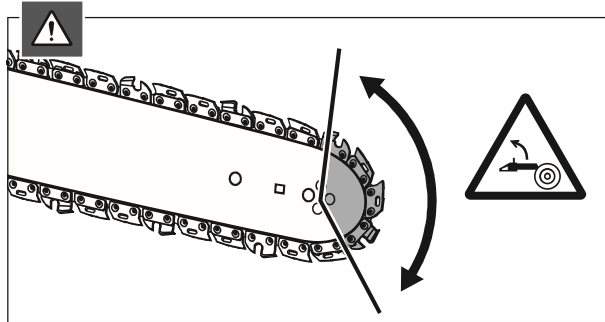

OPERATION

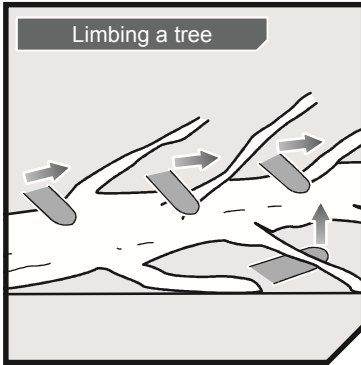

WARNING: Do not stand on any unstable surface while using the product. This could include, but is not limited to, ladders, scaffolds, and trees.

NOTE: Limbing is removing the branches from a fallen tree. When limbing leave larger lower limbs to support the log off the ground. Remove the small limbs in one cut. Branches under tension should be cut from the bottom up to avoid binding the product.

WARNING: A springpole is any log, branch, rooted stump, or sapling which is bent under tension by other wood so that it springs back if the wood holding it is cut or removed. On a fallen tree, a rooted stump has a high potential of springing back to the upright position during the bucking cut to separate the log from the stump. Watch out for springpoles—they are dangerous. Do not attempt to cut bent branches or stumps which are under tension unless you are professionally trained and competent to do so.

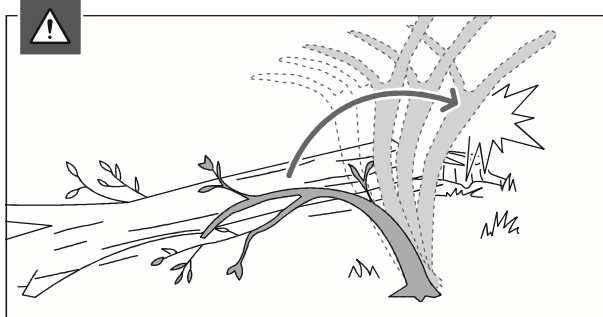
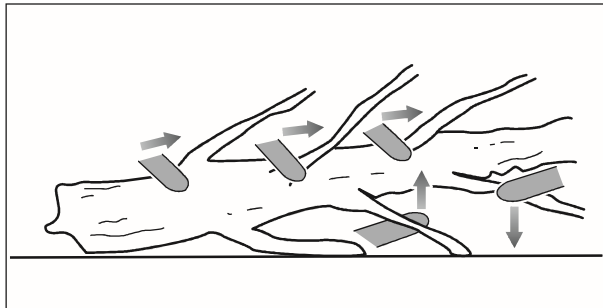

OPERATION

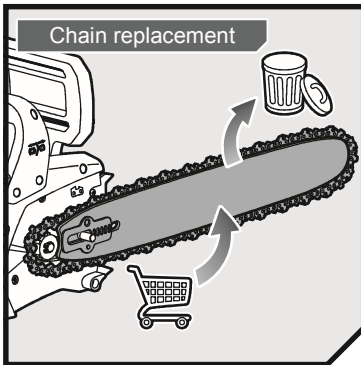

1. Disconnect the product from the power supply. Wear protective gloves.
2. Unlock the chain tension/guide bar locking knob by turning it counterclockwise until the sprocket cover comes loose.
3. Remove the sprocket cover. Remove the bar and saw chain from the product.
4. Remove the screw holding the guide bar to the chain tension assembly. Dispose the used bar and saw chain properly.

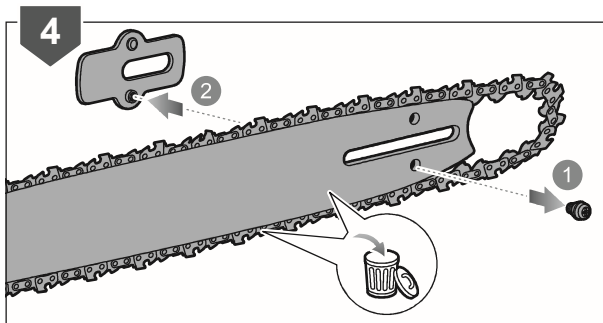
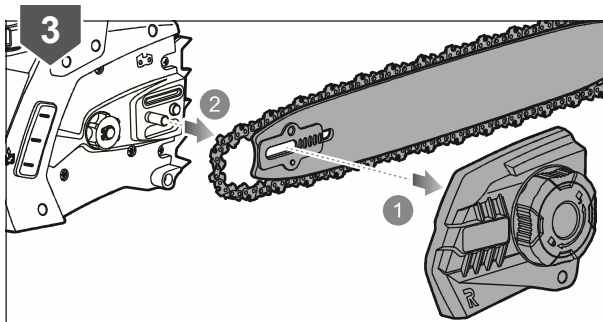
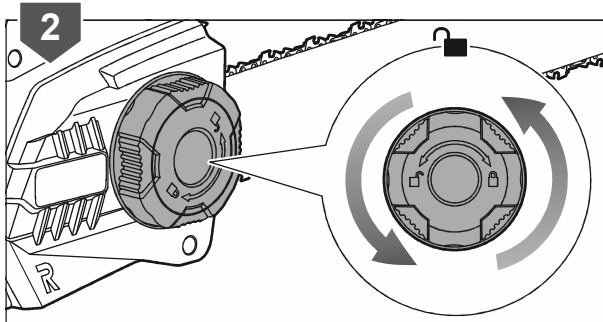
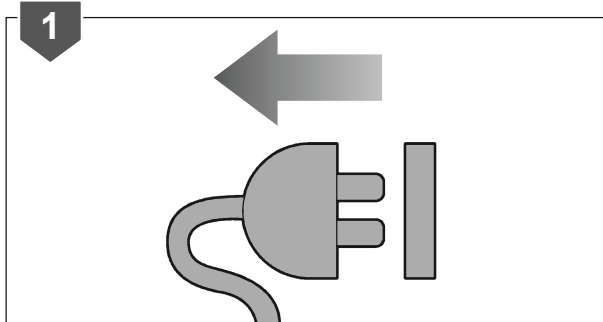

OPERATION

5. Mount the chain tension assembly on to the new bar and tighten the screw. Put the new chain in the correct direction onto the bar and make sure that the drive links are aligned in the bar groove.
6. Attach the bar to the chain saw and loop the chain around the drive sprocket. Replace the sprocket cover.
7. Tighten and lock the chain tension/guide bar locking knob by turning it clockwise. The chain tension is correct when the gap between the cutter in the chain and the bar is between 3 mm - 4 mm. Pull the chain in the middle of the lower side of the bar downwards (away from the bar) and measure the distance between the bar and the chain cutters. Adjust the chain tension. Refer to the "Adjusting chain tension" section.

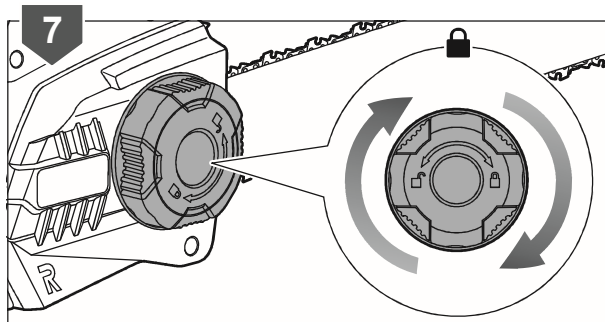
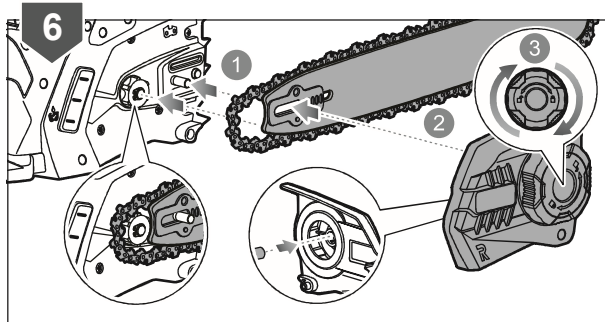
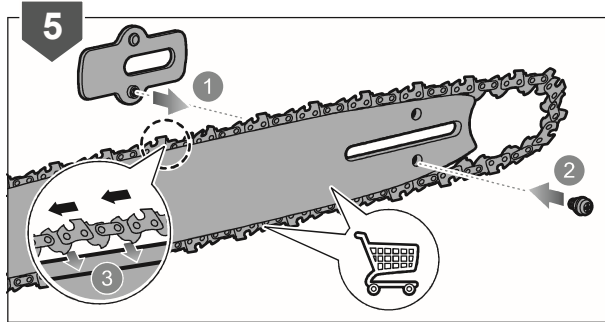

OPERATION

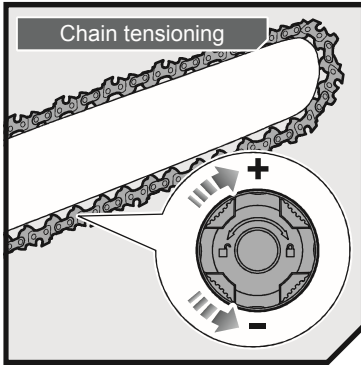

1. Disconnect the product from the power supply. Wear protective gloves.
2. To correct the chain tension, fully loosen the chain tension/guide bar locking knob, then tighten the chain tension/guide bar locking knob by turning it clockwise until it locks into place. Check the chain tension frequently.

The chain tension is correct when the gap between the cutter in the chain and the bar is between 3 mm - 4 mm. Pull the chain in the middle of the lower side of the bar downwards (away from the bar) and measure the distance between the bar and the chain cutters.

3. Tighten and lock the chain tension/guide bar locking knob by turning it clockwise.

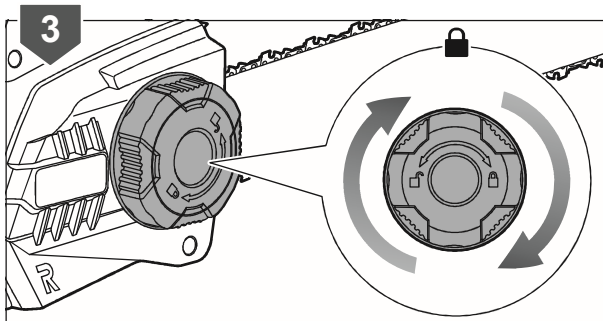
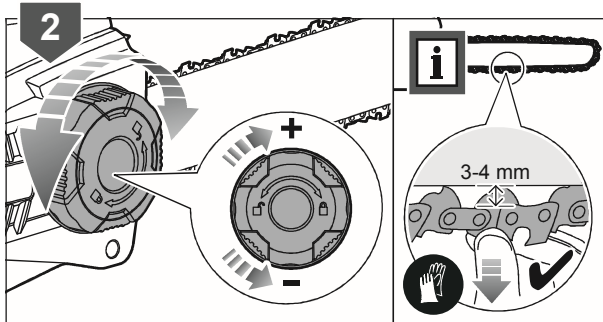
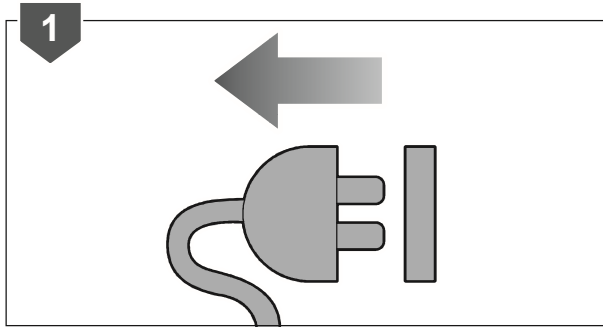

MAINTENANCE

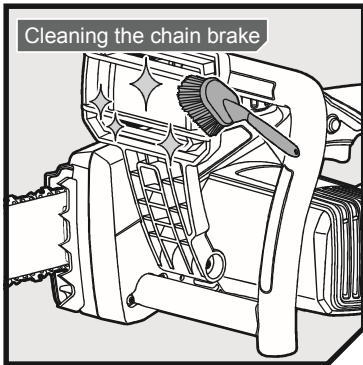

1. Disconnect the product from the power supply.
2. Brush as much loose dirt and sawdust from around the chain brake and sprocket as possible.

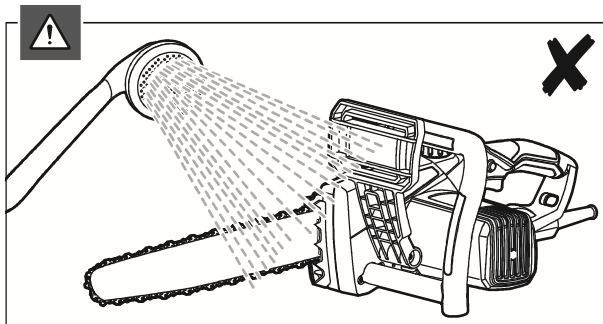
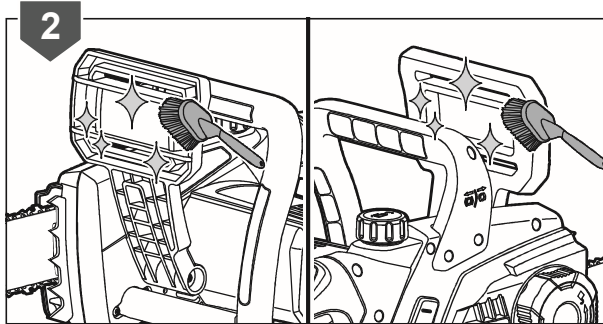
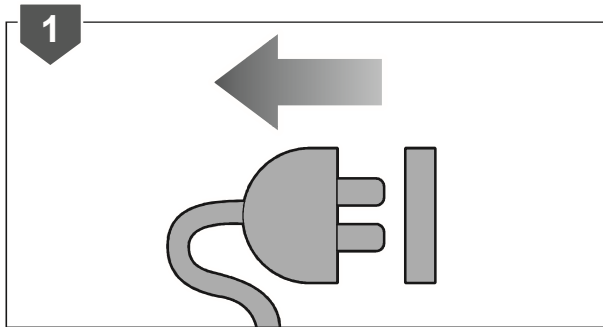

TRANSPORTATION

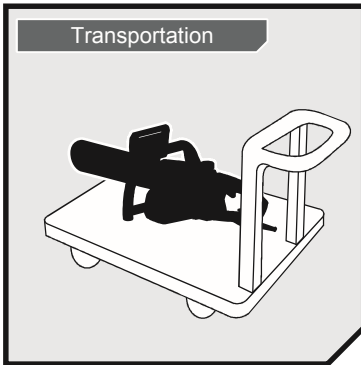

1. Stop the product and disconnect it from the power supply. Allow the product to cool down before transporting.
2. Always fit guide bar cover before storing the product, or during transportation.
3. Drain all bar and chain lubricant from the tank into a container approved for lubricant.
4. Remember to properly replace and tighten the bar and chain lubricant cap.

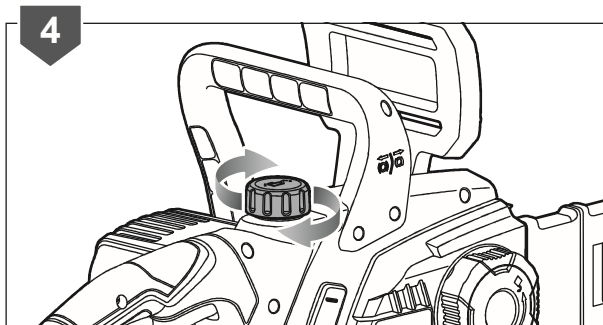
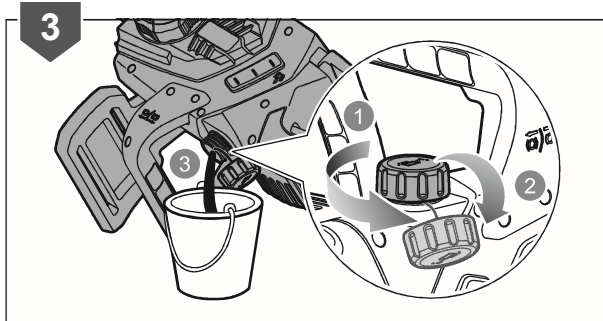
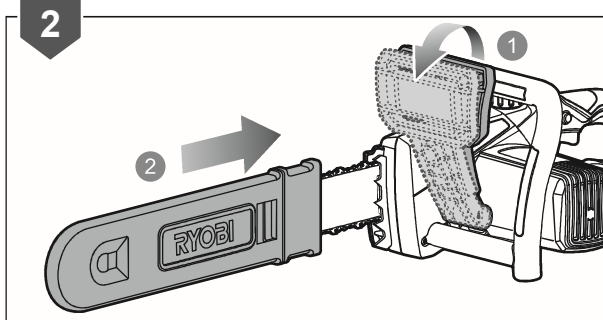
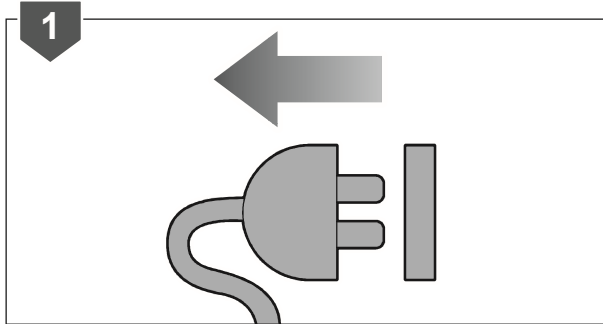

TRANSPORTATION

5. When transporting the product, secure it against movement or falling to prevent injury to persons or damage to the product.

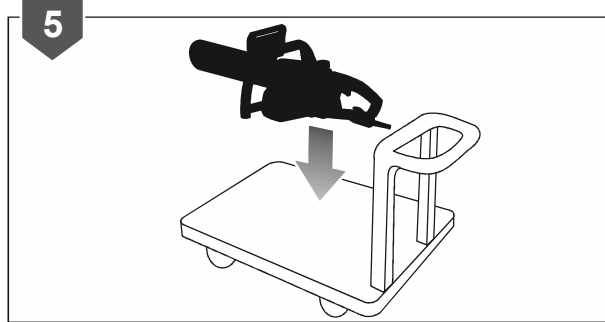

STORAGE

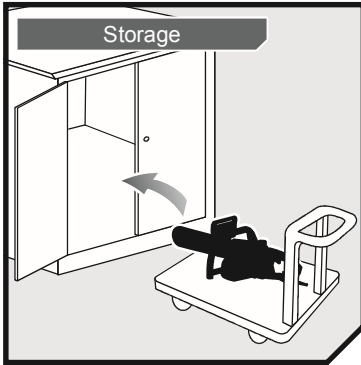

1. Stop the product and disconnect it from the power supply. Allow the product to cool down before storing.
2. Always fit guide bar cover before storing the product, or during transportation.
3. Drain all bar and chain lubricant from the tank into a container approved for lubricant.
4. Remember to properly replace and tighten the bar and chain lubricant cap.

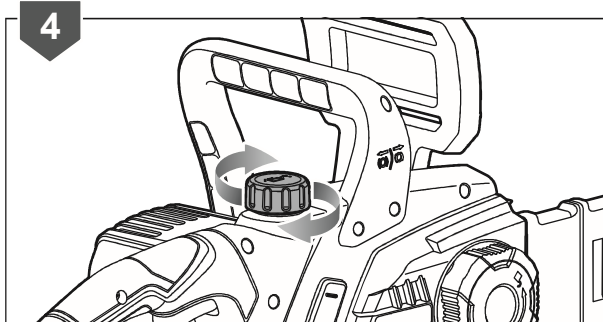
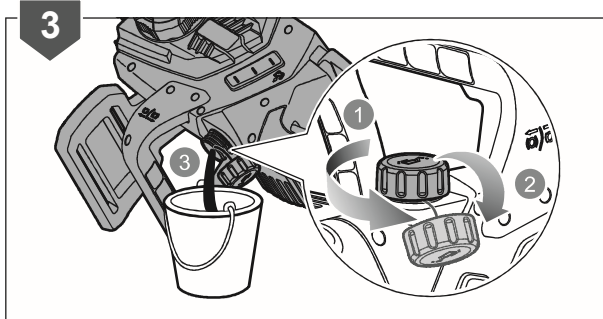
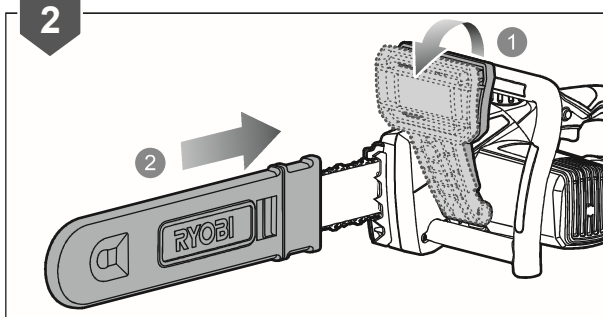
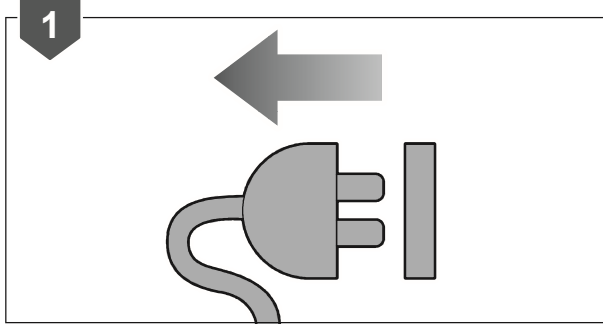

STORAGE

5. Store the product in a cool, dry, and well-ventilated place that is inaccessible to children. Keep away from corrosive agents such as garden chemicals and de-icing salts. Do not store outdoors.

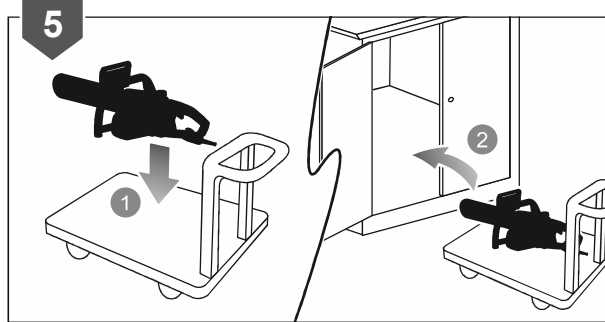

PRODUCT SPECIFICATIONS

Model	RCS2340B
Rated power	2300W
Rated voltage	230-240V ~50Hz
Guide bar length	406 mm (16")
Usable cutting length	350 mm (14")
Chain brake stop	<0.12 s
Chain speed	15 m/s
Chain oil tank capacity	150 ml
Weight (with guide bar, chain and empty tank)	4.8 kg
Vibration level	
Front handle	6.0 m/s ²
Rear handle	9.4 m/s ²
Uncertainty of measurement	1.5 m/s ²
Noise emission level	
A-weighted sound pressure level at operator's position	93 dB(A)
Uncertainty of measurement	3.0 dB(A)
A-weighted sound power level	104 dB(A)
Uncertainty of measurement	3.0 dB(A)

REPLACEMENT PART (BAR AND CHAIN)

Model	RCS2340B		
Manufacturer	OREGON	POWERFIT	SPARE P/N
Chain	91PJ056X	PWFTCA1602	-
Bar	160SDEA041	-	099184101021

Chain must be fitted with bar from the same manufacturer according to above combinations.

VIBRATION LEVEL

The declared vibration value has been measured with a standard test method and may be used to compare one tool with another.

The declared vibration value may be used in a preliminary assessment of exposure.

The vibration emission during actual use of power tool can differ from the declared total value depending on the ways in which the tool is used.

Identify safety measures to protect yourself based on an estimation of exposure in the actual conditions of use, taking account of all parts of the operating cycle such as the times when the tool is switched off and when it is running idle in addition to the trigger time.







Imported by:

Techtronic Industries Australia Pty Ltd
31 Gilby Road, Mount Waverley, VIC 3149
Melbourne, Australia

Techtronic Industries N.Z. Limited
2 Landing Drive, Mangere
Auckland, 2022, New Zealand

XXXXXXXXXXXX-XX